

GrandCurve W

CURVED ARCHITECTURAL ROOFING

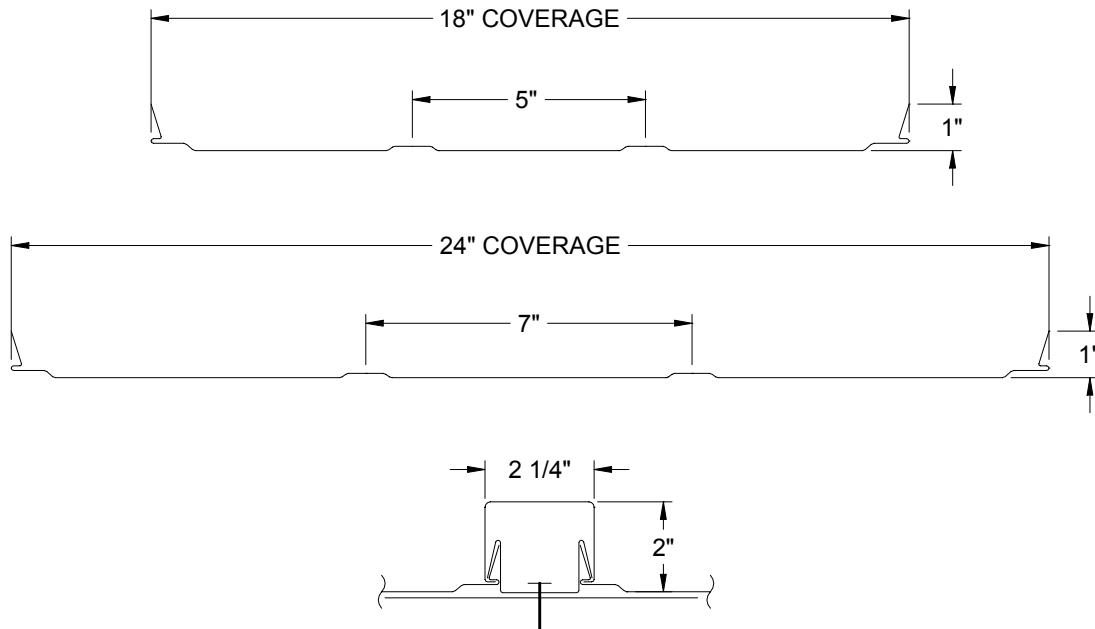

Effective September 2007



GRANDCURVE PANEL SEAM WITH WIDE CAP

GRAVITY LOAD TABLE - 24 ga. (STEEL) (psf)

width	6"	1' 0"	1' 3"	1' 6"	2' 0"	3' 9" *
16"	35	33	32	31	29	22
12"	47	44	42.5	41	39	32

GRAVITY LOAD TABLE - 24 ga. (ALUMINUM) (psf)

width	6"	1' 0"	1' 3"	1' 6"	2' 0"	3' 9" *
16"	25	23	22.5	22	20	13
12"	33	31	30	29	27	20

Notes:

- * Fabral recommends that clip spacing not exceed 2' 0".
- 1. Allowable loads are based on 1986 AISI specifications.
- 2. Allowable loads are based on stress only.
- 3. Clip spacing should account for clip and clip screw strength.

Jackson, GA (800) 884-4484
 Grapevine, TX (800) 477-9066
 Salem, OR (800) 477-8028
 Headquarters - Lancaster, PA (800) 477-2741

DESIGN INFORMATION

SUBSTRATE: panels require installation on a solid substrate (i.e., steel or plywood deck) with ice and water shield placed under the panels.

CURVING: minimum radius of panels is 15'-0" with additional forming at the factory for both the panel and the caps. Panels can be curved to a minimum radius of 35'-0" if they are curved in the field. All caps must be curved at the factory regardless of the radius.

FORMING: panels can be either field-formed or factory-formed at Fabral's option.

CLIP SPACING: maximum clip spacing is 2'-0".

TEST REPORT SUMMARY

ASTM E1592: 24 ga. steel panels (24" width) at 1' 3" and 3' 9" spans over open purlins. Design uplift loads for 24 ga. panels are 32.12 psf at 1' 3" clip spacing and 21.21 psf at 3' 9" clip spacing.

GRANDCURVE W SPECIFICATIONS

1.01 SUMMARY

- A. Section includes: all material, labor, and equipment to complete installation of GrandCurve curved roofing as shown on the drawings and herein specified. Include all copings, gutters, and flashings contiguous with the panels.
- B. Related Sections
 1. Metal decking
 2. Rough carpentry, plywood, and underlayment
 3. Insulation
 4. Membrane roofing
 5. Flashing and sheet metal
 6. Joint sealers: sealants and caulk
 7. Structural framing.

1.02 REFERENCES

- A. American Society for Testing and Materials (ASTM)
 1. ASTM A 653: Steel Sheet, Zinc-Coated by the Hot Dip Process
 2. ASTM A 792: Steel Sheet, Aluminum-Zinc Alloy Coated by the Hot Dip Process.
 3. ASTM B 209: Aluminum and Aluminum Alloy Sheet and Plate.
- B. Sheet Metal and Air Condition Contractors National Association, Inc. (SMACNA)
 1. SMACNA Architectural Sheet Metal Manual, 1993 Edition.
- C. American Iron and Steel Institute (AISI)
 1. AISI Cold Formed Steel Design Manual
- D. Aluminum Association
 1. Aluminum Design Manual
- E. Metal Construction Association (MCA)
 1. Preformed Metal Wall Guidelines
- F. Code references
 1. ASCE, Minimum Loads for Buildings and Other Structures
 2. BOCA National Building Code
 3. UBC Uniform Building Code
 4. SBC Standard Building Code

1.03 SYSTEM DESCRIPTION

- A. Performance Requirements: Provide factory formed, pre-finished, snap together, concealed clip, architectural standing seam metal roof system, that has been pre-tested and certified by manufacturer to comply with specified requirements under installed conditions.
- B. Structural Requirements: Engineer panels for structural properties in accordance with latest edition of American Iron and Steel Institute's Cold Formed Steel Design Manual using "effective width" concept and Aluminum Association's Aluminum Design Manual.

1.04 SUBMITTALS

- A. Product Data: submit manufacturer's specifications, standard profile sheet, product data brochure and finish warranty.
- B. Shop Drawings: shop drawings showing roof plan with layout of panels, clips, clip attachment, underlayment and sections of each flashing/trim condition shall be submitted for approval prior to fabrication. Drawings shall contain material type, metal thickness and finish. Drawings shall distinguish between factory and field fabrication.
- C. Samples:
 1. Submit sample 12" long x full width panel, showing proposed metal gauge, seam profile and specified finish.
 2. Submit manufacturers standard colors for Architect's selection.
- D. Certification: Submit manufacturer's certification that materials and finishes meet specification requirements.

1.05 QUALITY ASSURANCE

- A. Panel manufacturer shall have a minimum of ten (10) years of experience in manufacturing architectural roofing in a permanent stationary indoor facility.
- B. Panel installer shall have a minimum of two (2) years experience in the installation of concealed clip architectural standing seam metal roofing and show evidence of successful completion of at least three (3) projects of similar size, scope, and complexity.

1.06 DELIVERY, STORAGE, and HANDLING

- A. Panels and flashings shall be protected and properly packaged to protect against transportation damage in transit to the jobsite.
- B. Upon delivery, exercise care in unloading, stacking, moving, storing, and erecting panels and flashings to prevent twisting, bending, scratching, or denting.
- C. Store panels and flashings in a safe, dry environment under a waterproof covering to prevent water damage. Allow for adequate ventilation to prevent condensation. Panels and flashings with strippable film shall not be stored in direct sunlight.
- D. Upon exposure to direct sunlight, immediately remove strippable film from panels and flashings. Protect panels and flashings from foot traffic and from all other trades.

1.07 PROJECT CONDITIONS

- A. Field dimensions shall be taken prior to fabrication to verify jobsite conditions.
- B. Panels must be installed over a solid substrate.

1.08 WARRANTIES

- A. Panel manufacturer shall provide a twenty (20) year warranty on the paint finish covering chalking, cracking, checking, chipping, blistering, peeling, flaking, and fading.
- B. Applicator shall furnish written warranty for a two (2) year period from date of substantial completion of building covering repairs required to maintain roof and flashings in watertight conditions.

2.01 PRODUCT DESCRIPTION

- A. GrandCurve architectural, curved, snap-together standing seam panel as manufactured by Fabral, 3449 Hempland Road, Lancaster, PA 17601; ph.: 717-397-2741; fax: 717-397-1040.
- B. The seams of the roofing/siding/fascia system shall be 18" or 24" o.c. and shall be securely enclosed by wide, 2" tall x 2 1/4" wide batten covers. Each upturned leg of the pan shall be approximately 1" high. The bottom edges of the batten caps shall be crimped so that the batten covers will curve with the radius of the roof. All batten caps shall be custom-curved at the jobsite.
- C. The batten caps shall be of the same material, thickness, and coating as the pans. All batten caps shall be custom-curved at the jobsite.
- D. The minimum radius that the panels can be formed to is 15'.
- E. The panels shall have two stiffeners in the pan.

2.02 PRODUCT SUBSTITUTIONS

- A. Requests to use alternate systems shall be submitted in writing to the project designer at least ten (10) days prior to bid date. Request shall demonstrate proposed substitution meets or exceeds specified performance requirements. Certified statements, samples and descriptive data shall be included in this submittal request.
- B. Manufacturers listed in this section are pre-qualified manufacturers. Substitution of manufacturer's products for those specified shall not be allowed at anytime during

construction.

2.03 MATERIALS AND FINISHES

- A. Roof panel materials
 1. 24 or 22 gauge, Grade 50 (50 ksi yield strength) structural steel with G90 (0.90 oz./ft.2) hot dipped galvanized coating, both conforming to ASTM A 653.
 2. 24 or 22 ga., Grade 50 (50 ksi yield strength) structural steel with AZ50 (0.50 oz./ft.2) aluminum-zinc alloy coating, both conforming to ASTM A 792.
 3. 0.032", 3105-H14 aluminum or equivalent (20 ksi yield strength) aluminum alloy conforming to ASTM B 209.
- B. Texture: panels shall be smooth.
- C. Finish: Refer to manufacturer's standard color card to determine appropriate finish and color. All panels shall receive a factory-applied Kynar® 500/Hylar® 5000* conforming to the following:
 1. Metal preparation: all metal shall have the surfaces carefully prepared for painting on a continuous process coil coating line by alkali cleaning, hot water rinsing, application of chemical conversion coating, cold water rinsing, sealing with an acid rinse, and thorough drying.
 2. Prime coating: a base coat of epoxy paint, specifically formulated to interact with the top-coat, shall be applied to the prepared surfaces by roll coating to a dry film thickness of 0.20 ± 0.05 mils. This prime coat shall be oven cured prior to application of finish coat.
 3. Exterior coating: a Kynar® 500/Hylar® 5000 finish coating shall be applied over the primer by roll coating to a dry film thickness of 0.80 ± 0.05 mils for a total dry film thickness of 1.00 ± 0.10. This finish coating shall be oven-cured.
 4. Interior coating: a washcoat shall be applied on the reverse side over the primer by roll coating to a dry film thickness of 0.30 ± 0.05 mils for a total dry film thickness of 0.50 ± 0.10 mils. The washcoat shall be oven-cured.
 5. Color: the color of the exterior finish shall be _____ as chosen from the manufacturer's standard color chart.
 6. Physical properties: the coating shall conform to the manufacturer's standard performance criteria as listed by certified test reports for fade, chalk, abrasion, humidity, adhesion, pollution resistance, and others as required and standard within the industry.

2.04 ACCESSORIES

- A. Concealed roof clips shall be made from 18 ga. steel with zinc-aluminum alloy coating. Clip length shall be 2". The clip shall have two hems that hold adjacent panels. The clip shall be symmetrical. Clips shall be one-piece and permit unlimited panel thermal movement.
- B. Flashing and Trim
 1. All flashing and trim shall be of the same material, gauge, finish, and color as the roof panels and fabricated in accordance with standard SMACNA procedure and details.
 2. Fabricate gutters and downspouts in the same gauge, material, finish, and color as the roof panels.
- C. Fasteners
 1. Clips to substrate: screw shall be #10 or #12 diameter, self tapping type, zinc-plated steel.
 2. Flashings to panels: exposed screws shall be zinc plated with a #14 x 1" A-point screw with combination steel and neoprene washer, color to match panel.
- D. Caulking shall be a polyurethane where it is exposed and there is no thermal movement. All caulking or sealing shall be done in a neat manner with excess caulking or sealant removed from exposed surfaces.
- E. Caulking shall be non-skinning, non-hardening gun grade butyl sealant or butyl sealant tape with a minimum thickness of 1/4" where it is concealed and where thermal movement must be accommodated. All caulking or sealing shall be done in a neat manner with excess caulking or sealant removed from exposed surfaces.

2.05 RELATED MATERIALS

- A. Refer to other sections listed in Related Sections paragraph for related materials.

2.06 FABRICATION

- A. Endlaps in the pan will not be allowed. Endlaps in the caps are permissible.
- B. When required, metal roofing/siding/fascia panels and battens shall be field- formed on the jobsite in continuous lengths by the manufacturer's machinery and personnel. Portable rollformers, rented or owned by the installer, are not acceptable.
- C. Fabricate flashings from the same material as the roof system.

2.07 SOURCE QUALITY

- A. Source Quality: obtain metal panels and accessories from a single manufacturer.
- B. Fabrication tolerances: follow tolerances in MCA's Preformed Metal Wall Guidelines.
- C. Tests and inspections
- D. Verification of performance

3.01 MANUFACTURER'S INSTRUCTIONS

- A. Compliance: Comply with manufacturer's product data, including product technical bulletins, product catalog installation instructions, and product cartons for installation.

3.02 EXAMINATION

- A. Installer shall:
 1. Inspect roof deck to verify deck layout complies with shop drawing layout and is smooth, even, sound, and free of depressions.
 2. Report variations and potential problems in writing to the architect.

3.03 INSTALLATION

- A. Conform to the standard set forth in the SMACNA architectural sheet metal manuals and the approved shop drawings detailed for the project.
- B. Install panels plumb, level, and straight with the seams parallel, conforming to the design as indicated.
- C. Install panel system so it is watertight, without waves, warps, buckles or distortions, and allow for thermal movement considerations.
- D. Abrasive devices shall not be used to cut on or near roof panel system.
- E. Apply sealant tape or caulking as necessary at flashing and panel joints to prevent water penetration.
- F. Remove any strippable film immediately upon exposure to direct sunlight.
- G. Vapor retarder: the joints, perimeter, and all openings shall be sealed per the manufacturer's instructions to provide a continuous vapor retarder.
- H. Install panels on a solid substrate only.
- I. Underlayment (solid substrate):
 1. Provide ice and water shield membrane under entire roofing.
 2. Lay parallel to ridge line with 2 1/4" horizontal laps and 6" vertical laps

3.04 CLEANING

- A. Dispose of excess materials and debris from jobsite.
- B. Remove filings, grease, stains, marks, or excess sealants from roof panel system to prevent staining.
- C. Protect work from damage from other trades until final acceptance.

* Kynar® 500 is a registered trademark of Elf Atochem North America, Inc.
Hylar® 5000 is a registered trademark of Ausimont USA, Inc.